

## TFT LCD Approval Specification

# MODEL NO.: M200O1-P02

Customer : \_\_\_\_\_

Approved by : \_\_\_\_\_

Note :

核准時間	部門	審核	角色	投票
2009-11-30 19:09:28	MTR 產品管理處		Director	Accept

## - CONTENTS -

REVISION HISTORY	3
1. GENERAL DESCRIPTION	4
1.1 OVERVIEW	
1.2 FEATURES	
1.3 APPLICATION	
1.4 GENERAL SPECIFICATIONS	
1.5 MECHANICAL SPECIFICATIONS	
2. ABSOLUTE MAXIMUM RATINGS	5
2.1 ABSOLUTE RATINGS OF ENVIRONMENT (BASED ON CMO MODULE M200O1-L02)	
2.2 ABSOLUTE RATINGS OF ENVIRONMENT (OPEN CELL)	
2.3 ELECTRICAL ABSOLUTE RATINGS (OPEN CELL)	
3. ELECTRICAL CHARACTERISTICS	7
3.1 TFT LCD OPEN CELL	
3.2 V <sub>cc</sub> POWER DIP CONDITION	
4. BLOCK DIAGRAM	9
4.1 TFT LCD OPEN CELL	
5. INPUT TERMINAL PIN ASSIGNMENT	10
5.1 TFT LCD MODULE	
5.2 LVDS DATA MAPPING TABLE	
5.3 COLOR DATA INPUT ASSIGNMENT	
6. INTERFACE TIMING	13
6.1 INPUT SIGNAL TIMING SPECIFICATIONS	
6.2 POWER ON/OFF SEQUENCE	
7. OPTICAL CHARACTERISTICS	16
7.1 TEST CONDITIONS	
7.2 OPTICAL SPECIFICATIONS	
7.3 FLICKER ADJUSTMENT	
8. PACKAGING	21
8.1 PACKING SPECIFICATIONS	
8.2 PACKING METHOD	
9. DEFINITION OF LABELS	22
9.1 OPEN CELL LABEL	
9.2 CARTON LABEL	
10. RELIABILITY TEST	23
11. PRECAUTIONS	24
11.1 ASSEMBLY AND HANDLING PRECAUTIONS	
11.2 SAFETY PRECAUTIONS	
11.3 OTHER	
12. MECHANICAL DRAWING	25

### REVISION HISTORY

Version	Date	Section	Description
Ver. 2.0	May, 22 '09	-	M200O1-P02 Approval Specifications was first issued.
Ver. 2.1	Aug, 27 '09	3.1	Updated TFT LCD Electrical characteristics.
		6.1	Updated Input signal Timing Specifications.
		8.1	Updated Packing Specifications.
		8.2	Updated Packing method.
		10	Added RELIABILITY TEST.
Ver 2.2	Nov, 18 '09	5.1	Added aging mode pin and input voltage.
		7	Modified Optical characteristics.

## 1. GENERAL DESCRIPTION

### 1.1 OVERVIEW

The M200O1-P02 is a 20-inch wide TFT LCD cell with driver ICs and a 30-pins-2ch-LVDS circuit board. The product supports 1600 x 900 HD+ (16:9 wide screen) mode and can display up to 16.7M colors. The backlight unit is not built in.

### 1.2 FEATURES

- Extra-wide viewing angle
- High contrast ratio
- Fast response time
- High color saturation
- HD+ (1600 x 900 pixels) resolution
- DE (Data Enable) only mode
- LVDS (Low Voltage Differential Signaling) interface
- RoHS Compliance

### 1.3 APPLICATION

- TFT LCD Monitor
- TFT LCD TV

### 1.4 GENERAL SPECIFICATIONS

Item	Specification	Unit	Note
Diagonal Size	20.0	inch	
Active Area	442.8 (H) x 249.075 (V)	mm	(1)
Driver Element	a-si TFT active matrix	-	-
Pixel Number	1600 x R.G.B. x 900	pixel	-
Pixel Pitch	0.2768 (H) x 0.2768 (V)	mm	-
Pixel Arrangement	RGB vertical stripe	-	-
Display Colors	16.7M	color	-
Transmissive Mode	Normally White	-	-
Surface Treatment	Hard coating (3H), Anti-glare (Haze 25%)	-	-
Power Consumption	6	Watt	(3)

### 1.5 MECHANICAL SPECIFICATIONS

Item	Min.	Typ.	Max.	Unit	Note
Weight	-	-	520	g	-
I/F connector mounting position	The mounting inclination of the connector makes the screen center within $\pm 0.5\text{mm}$ as the horizontal.			-	(2)

Note (1) Please refer to the attached drawings for more information of front and back outline dimensions.

(2) Connector mounting position

(3) Please refer to sec.3.1 for more information of power consumption.

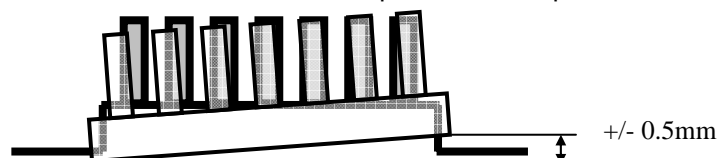

## 2. ABSOLUTE MAXIMUM RATINGS

### 2.1 ABSOLUTE RATINGS OF ENVIRONMENT (BASED ON CMO MODULE M200O1-L02)

Item	Symbol	Value		Unit	Note
		Min.	Max.		
Storage Temperature	T <sub>ST</sub>	-20	+60	°C	(1)
Operating Ambient Temperature	T <sub>OP</sub>	0	+50	°C	(1), (2)

Note (1) Temperature and relative humidity range is shown in the figure below.

- (a) 90 %RH Max. (Ta ≤ 40 °C).
- (b) Wet-bulb temperature should be 39 °C Max. (Ta > 40 °C).
- (c) No condensation.

Note (2) The temperature of panel display surface area should be 0 °C Min. and 60 °C Max.

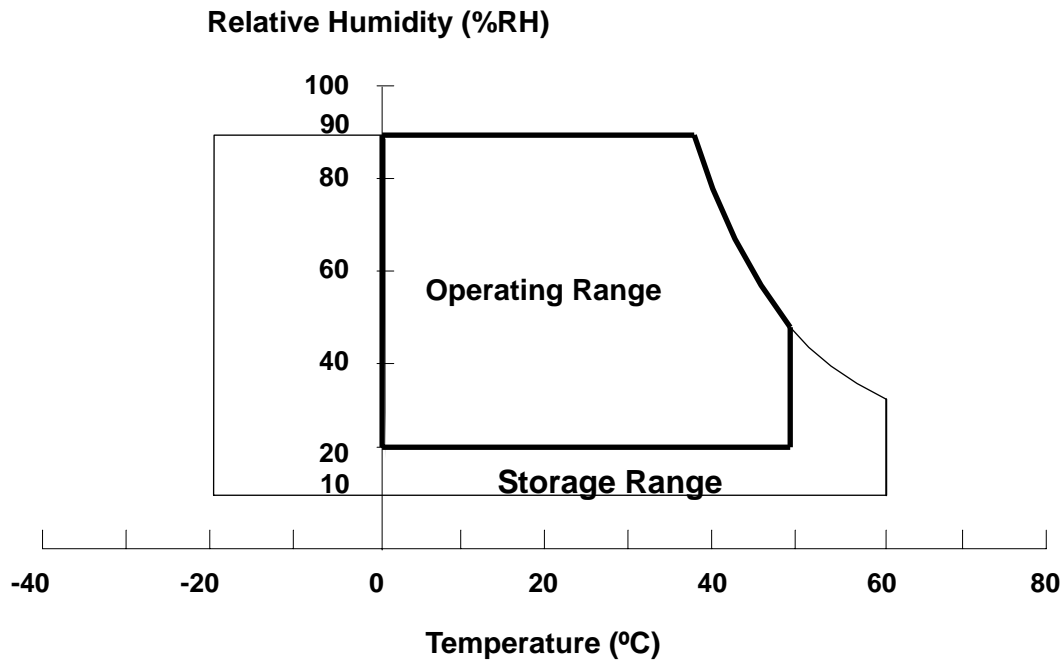

## 2.2 ABSOLUTE RATINGS OF ENVIRONMENT (OPEN CELL)

High temperature or humidity may reduce the performance of panel. Please store LCD panel within the specified storage conditions.

Storage Condition: With packing.

Storage temperature range:  $25\pm 5$  °C.

Storage humidity range:  $50\pm 10\%$ RH.

Shelf life: 30days

## 2.3 ELECTRICAL ABSOLUTE RATINGS (OPEN CELL)

Item	Symbol	Value		Unit	Note
		Min	Max		
Power Supply Voltage	$V_{CC}$	-0.3	+5.5	V	(1)

Note (1) Permanent damage might occur if the module is operated at conditions exceeding the maximum values.

### 3. ELECTRICAL CHARACTERISTICS

#### 3.1 TFT LCD MODULE

 $T_a = 25 \pm 2 \text{ }^\circ\text{C}$ 

Parameter	Symbol	Value			Unit	Note
		Min.	Typ.	Max.		
Power Supply Voltage	V <sub>CC</sub>	4.5	5.0	5.5	V	-
Ripple Voltage	V <sub>RP</sub>	-	-	200	mV	-
Power on Rush Current	I <sub>RUSH</sub>	-	-	3.0	A	(2)
Power Supply Current	White	-	0.5	0.6	A	(3)a
	Black	-	0.9	1.1	A	(3)b
	Vertical Stripe	-	0.94	1.15	A	(3)c
Power Consumption	PLCD	-	4.7	5.75	Watt	(4)
LVDS differential input voltage	V <sub>id</sub>	100	-	600	mV	-
LVDS common input voltage	V <sub>ic</sub>	1.0	1.2	1.4	V	-

Note (1) The module should be always operated within above ranges.

Note (2) Power on rush current measurement conditions:

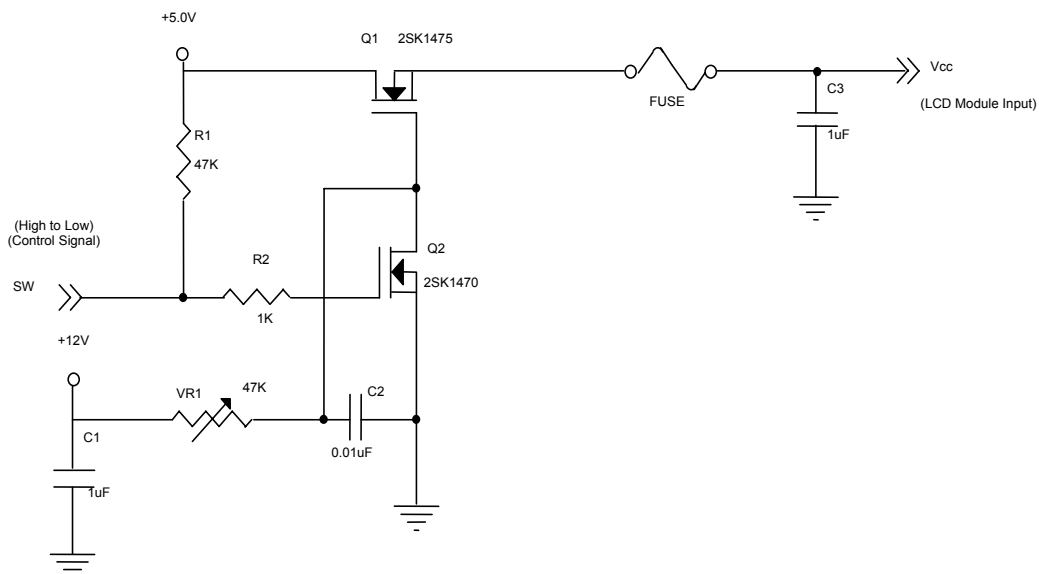

**Vcc rising time is 470μs**

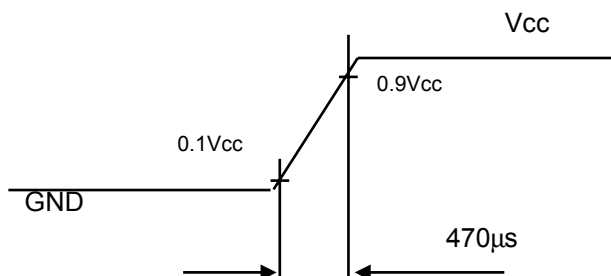

Note (3) The specified power supply current is under the conditions at  $V_{cc} = 5.0\text{ V}$ ,  $T_a = 25 \pm 2\text{ }^\circ\text{C}$ ,  $f_v = 60\text{ Hz}$ , whereas a power dissipation check pattern below is displayed.

a. White Pattern



Active Area

b. Black Pattern



Active Area

c. Vertical Stripe Pattern

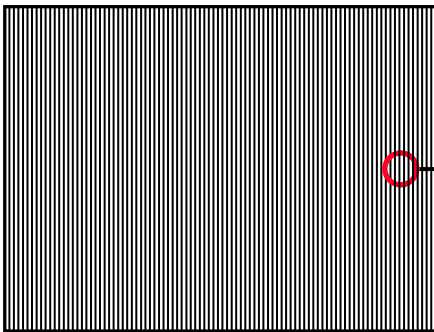

Active Area

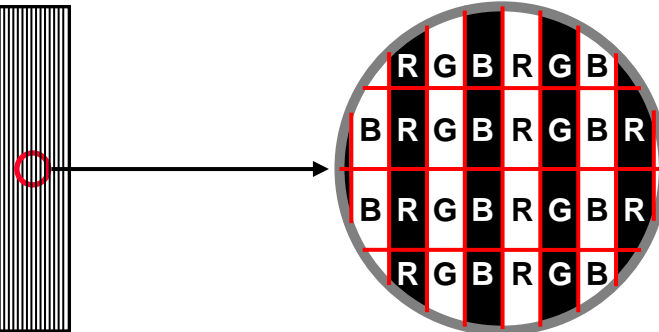

Note (4) The power consumption is specified at the pattern with the maximum current

3.2  $V_{cc}$  Power Dip Condition:

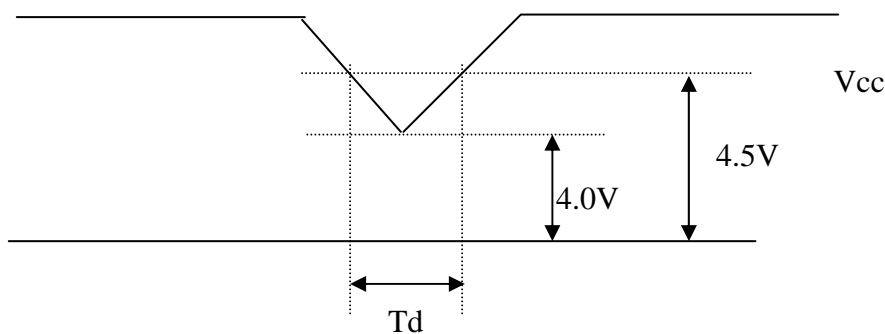

Dip condition:  $4.0\text{V} \leq V_{cc} \leq 4.5\text{V}$ ,  $T_d \leq 20\text{ms}$

#### 4. BLOCK DIAGRAM

##### 4.1 TFT LCD OPEN CELL

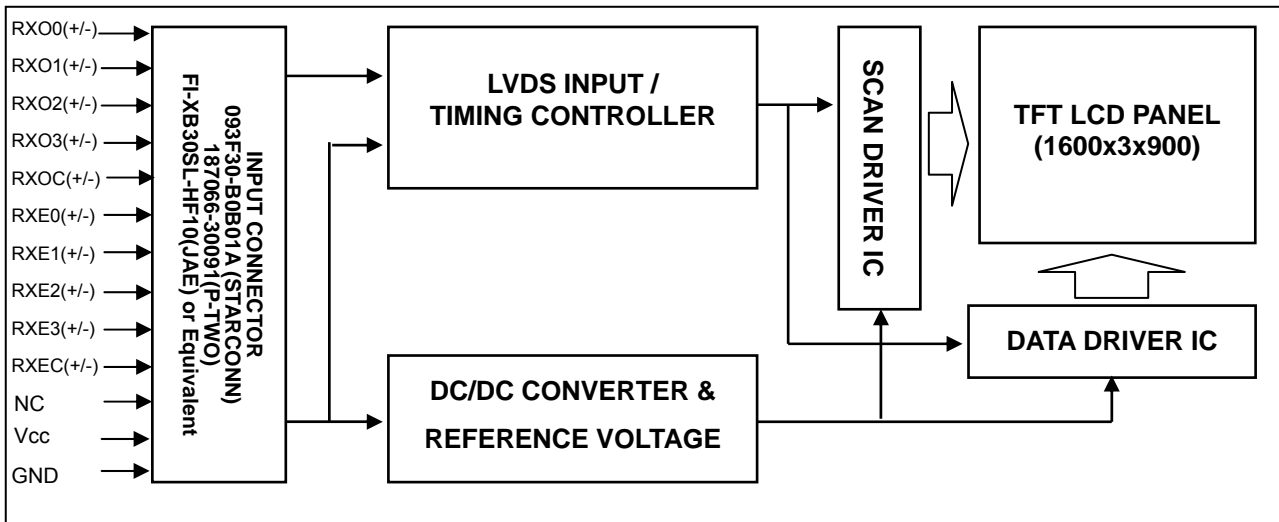

## 5. INPUT TERMINAL PIN ASSIGNMENT

### 5.1 TFT LCD MODULE

Pin	Name	Description
1	RXO0-	Negative LVDS differential data input. Channel O0 (odd)
2	RXO0+	Positive LVDS differential data input. Channel O0 (odd)
3	RXO1-	Negative LVDS differential data input. Channel O1 (odd)
4	RXO1+	Positive LVDS differential data input. Channel O1 (odd)
5	RXO2-	Negative LVDS differential data input. Channel O2 (odd)
6	RXO2+	Positive LVDS differential data input. Channel O2 (odd)
7	GND	Ground
8	RXOC-	Negative LVDS differential clock input. (odd)
9	RXOC+	Positive LVDS differential clock input. (odd)
10	RXO3-	Negative LVDS differential data input. Channel O3(odd)
11	RXO3+	Positive LVDS differential data input. Channel O3 (odd)
12	RXE0-	Negative LVDS differential data input. Channel E0 (even)
13	RXE0+	Positive LVDS differential data input. Channel E0 (even)
14	GND	Ground
15	RXE1-	Negative LVDS differential data input. Channel E1 (even)
16	RXE1+	Positive LVDS differential data input. Channel E1 (even)
17	GND	Ground
18	RXE2-	Negative LVDS differential data input. Channel E2 (even)
19	RXE2+	Positive LVDS differential data input. Channel E2 (even)
20	RXEC-	Negative LVDS differential clock input. (even)
21	RXEC+	Positive LVDS differential clock input. (even)
22	RXE3-	Negative LVDS differential data input. Channel E3 (even)
23	RXE3+	Positive LVDS differential data input. Channel E3 (even)
24	GND	Ground
25	NC	Not connection, this pin should be open.
26	NC	Not connection, this pin should be open.
27	NC/Agmode	Not connection, this pin should be open. When use Agmode pin, input voltage should be $3.3\pm 0.3V$ , otherwise connected to ground if not used.
28	Vcc	+5.0V power supply
29	Vcc	+5.0V power supply
30	Vcc	+5.0V power supply

Note (1) Connector Part No.: 093F30-B0B01A (STARCONN) 187066-30091(P-TWO) FI-XB30SL-HF10(JAE)  
or Equivalent

Note (2) The first pixel is odd.

Note (3) Input signal of even and odd clock should be the same timing.

Note (4) Permanent damage might occur if the Agmode is operated at conditions exceeding the maximum values.

## 5.2 LVDS DATA MAPPING TABLE

LVDS Channel O0	LVDS output	D7	D6	D4	D3	D2	D1	D0
	Data order	OG0	OR5	OR4	OR3	OR2	OR1	OR0
LVDS Channel O1	LVDS output	D18	D15	D14	D13	D12	D9	D8
	Data order	OB1	OB0	OG5	OG4	OG3	OG2	OG1
LVDS Channel O2	LVDS output	D26	D25	D24	D22	D21	D20	D19
	Data order	DE	NA	NA	OB5	OB4	OB3	OB2
LVDS Channel O3	LVDS output	D23	D17	D16	D11	D10	D5	D27
	Data order	NA	OB7	OB6	OG7	OG6	OR7	OR6
LVDS Channel E0	LVDS output	D7	D6	D4	D3	D2	D1	D0
	Data order	EG0	ER5	ER4	ER3	ER2	ER1	ER0
LVDS Channel E1	LVDS output	D18	D15	D14	D13	D12	D9	D8
	Data order	EB1	EB0	EG5	EG4	EG3	EG2	EG1
LVDS Channel E2	LVDS output	D26	D25	D24	D22	D21	D20	D19
	Data order	DE	NA	NA	EB5	EB4	EB3	EB2
LVDS Channel E3	LVDS output	D23	D17	D16	D11	D10	D5	D27
	Data order	NA	EB7	EB6	EG7	EG6	ER7	ER6

### 5.3 COLOR DATA INPUT ASSIGNMENT

The brightness of each primary color (red, green and blue) is based on the 8-bit gray scale data input for the color. The higher the binary input, the brighter the color. The table below provides the assignment of color versus data input.

Color		Data Signal																							
		Red								Green								Blue							
		R7	R6	R5	R4	R3	R2	R1	R0	G7	G6	G5	G4	G3	G2	G1	G0	B7	B6	B5	B4	B3	B2	B1	B0
Basic Colors	Black	0	0	0	0	0	0	0	0	0	0	0	0	0	0	0	0	0	0	0	0	0	0	0	0
	Red	1	1	1	1	1	1	1	1	0	0	0	0	0	0	0	0	0	0	0	0	0	0	0	0
	Green	0	0	0	0	0	0	0	0	1	1	1	1	1	1	1	1	0	0	0	0	0	0	0	0
	Blue	0	0	0	0	0	0	0	0	0	0	0	0	0	0	0	0	1	1	1	1	1	1	1	1
	Cyan	0	0	0	0	0	0	0	0	1	1	1	1	1	1	1	1	1	1	1	1	1	1	1	1
	Magenta	1	1	1	1	1	1	1	1	0	0	0	0	0	0	0	0	1	1	1	1	1	1	1	1
	Yellow	1	1	1	1	1	1	1	1	1	1	1	1	1	1	1	1	0	0	0	0	0	0	0	0
	White	1	1	1	1	1	1	1	1	1	1	1	1	1	1	1	1	1	1	1	1	1	1	1	1
Gray Scale Of Red	Red(0) / Dark	0	0	0	0	0	0	0	0	0	0	0	0	0	0	0	0	0	0	0	0	0	0	0	
	Red(1)	0	0	0	0	0	0	0	1	0	0	0	0	0	0	0	0	0	0	0	0	0	0	0	
	Red(2)	0	0	0	0	0	0	1	0	0	0	0	0	0	0	0	0	0	0	0	0	0	0	0	
	:	:	:	:	:	:	:	:	:	:	:	:	:	:	:	:	:	:	:	:	:	:	:	:	
	:	:	:	:	:	:	:	:	:	:	:	:	:	:	:	:	:	:	:	:	:	:	:	:	
	:	:	:	:	:	:	:	:	:	:	:	:	:	:	:	:	:	:	:	:	:	:	:	:	
	Red(253)	1	1	1	1	1	1	0	1	0	0	0	0	0	0	0	0	0	0	0	0	0	0	0	
	Red(254)	1	1	1	1	1	1	1	0	0	0	0	0	0	0	0	0	0	0	0	0	0	0	0	
Red(255)	1	1	1	1	1	1	1	1	0	0	0	0	0	0	0	0	0	0	0	0	0	0	0		
Gray Scale Of Green	Green(0) / Dark	0	0	0	0	0	0	0	0	0	0	0	0	0	0	0	0	0	0	0	0	0	0	0	
	Green(1)	0	0	0	0	0	0	0	0	0	0	0	0	0	0	1	0	0	0	0	0	0	0	0	
	Green(2)	0	0	0	0	0	0	0	0	0	0	0	0	0	1	0	0	0	0	0	0	0	0	0	
	:	:	:	:	:	:	:	:	:	:	:	:	:	:	:	:	:	:	:	:	:	:	:	:	
	:	:	:	:	:	:	:	:	:	:	:	:	:	:	:	:	:	:	:	:	:	:	:	:	
	:	:	:	:	:	:	:	:	:	:	:	:	:	:	:	:	:	:	:	:	:	:	:	:	
	Green(253)	0	0	0	0	0	0	0	0	1	1	1	1	1	1	0	1	0	0	0	0	0	0	0	
	Green(254)	0	0	0	0	0	0	0	0	1	1	1	1	1	1	1	0	0	0	0	0	0	0	0	
Green(255)	0	0	0	0	0	0	0	0	1	1	1	1	1	1	1	1	0	0	0	0	0	0	0		
Gray Scale Of Blue	Blue(0) / Dark	0	0	0	0	0	0	0	0	0	0	0	0	0	0	0	0	0	0	0	0	0	0	0	
	Blue(1)	0	0	0	0	0	0	0	0	0	0	0	0	0	0	0	0	0	0	0	0	0	0	1	
	Blue(2)	0	0	0	0	0	0	0	0	0	0	0	0	0	0	0	0	0	0	0	0	0	1	0	
	:	:	:	:	:	:	:	:	:	:	:	:	:	:	:	:	:	:	:	:	:	:	:	:	
	:	:	:	:	:	:	:	:	:	:	:	:	:	:	:	:	:	:	:	:	:	:	:	:	
	:	:	:	:	:	:	:	:	:	:	:	:	:	:	:	:	:	:	:	:	:	:	:	:	
	Blue(253)	0	0	0	0	0	0	0	0	0	0	0	0	0	0	0	1	1	1	1	1	1	1	0	
	Blue(254)	0	0	0	0	0	0	0	0	0	0	0	0	0	0	0	1	1	1	1	1	1	1	0	
Blue(255)	0	0	0	0	0	0	0	0	0	0	0	0	0	0	0	1	1	1	1	1	1	1	1		

Note (1) 0: Low Level Voltage, 1: High Level Voltage

## 6. INTERFACE TIMING

### 6.1 INPUT SIGNAL TIMING SPECIFICATIONS

The input signal timing specifications are shown as the following table and timing diagram.

Signal	Item	Symbol	Min.	Typ.	Max.	Unit	Note
LVDS Clock	Frequency	$F_c$	48.3	59.2	75.7	MHz	-
	Period	$T_c$	-	16.89	-	ns	-
	Input cycle to cycle jitter	$T_{rcj}$	-	-	+2% $T_c$	ps	(1)
	Spread spectrum modulation range	$F_{clk_{in\_mod}}$	-2% $F_c$	-	+2% $F_c$	MHz	(2)
	Spread spectrum modulation frequency	$F_{SSM}$	-	-	200	KHz	
	High Time	$T_{ch}$	-	4/7	-	$T_c$	-
	Low Time	$T_{cl}$	-	3/7	-	$T_c$	-
LVDS Data	Setup Time	$T_{lvs}$	400	-	-	ps	(3)
	Hold Time	$T_{lvh}$	400	-	-	ps	
Vertical Active Display Term	Frame Rate	$F_r$	50	60	75	Hz	-
	Total	$T_v$	929	934	942	Th	$T_v = T_{vd} + T_{vb}$
	Display	$T_{vd}$	900	900	900	Th	-
	Blank	$T_{vb}$	$T_v - T_{vd}$	$T_v - T_{vd}$	$T_v - T_{vd}$	Th	-
Horizontal Active Display Term	Total	$T_h$	1040	1056	1072	Tc	$T_h = T_{hd} + T_{hb}$
	Display	$T_{hd}$	800	800	800	Tc	-
	Blank	$T_{hb}$	$T_h - T_{hd}$	$T_h - T_{hd}$	$T_h - T_{hd}$	Tc	-

Note: Because this module is operated by DE only mode, Hsync and Vsync input signals are ignored.

### INPUT SIGNAL TIMING DIAGRAM

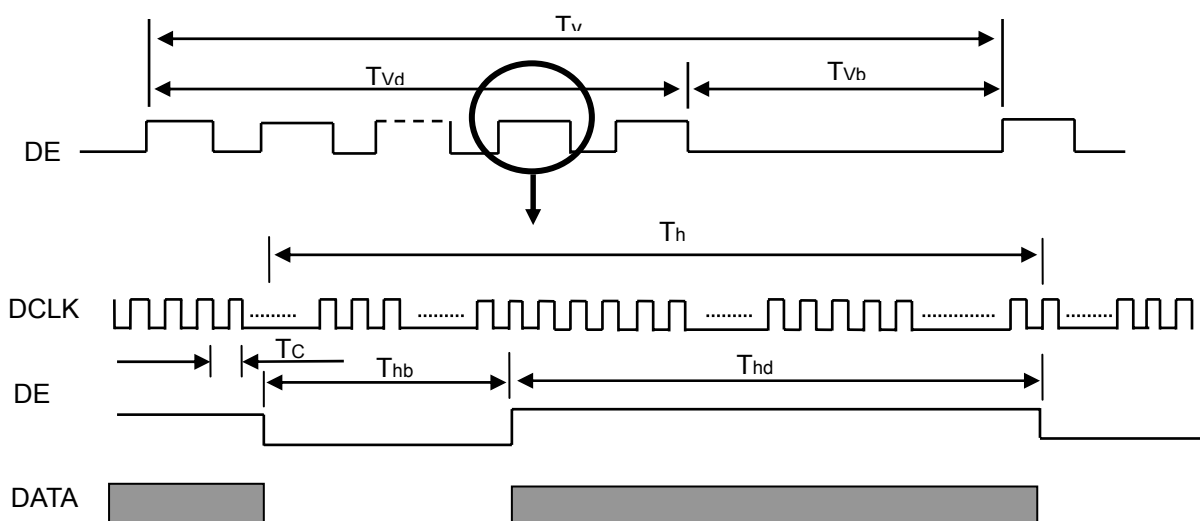

Note (1) The input clock cycle-to-cycle jitter is defined as below figures.  $Trcl = |T_1 - T|$

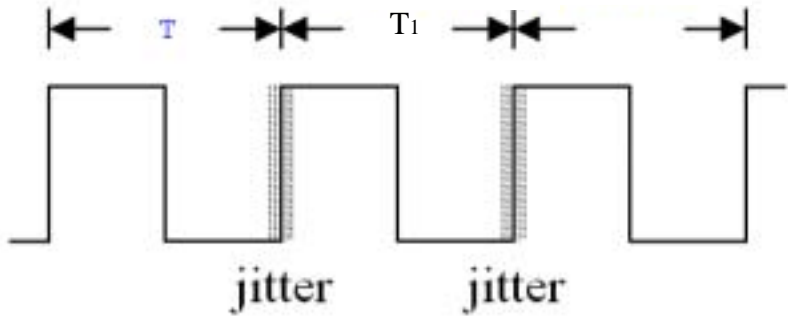

Note (2) The SSCG (Spread spectrum clock generator) is defined as below figures.

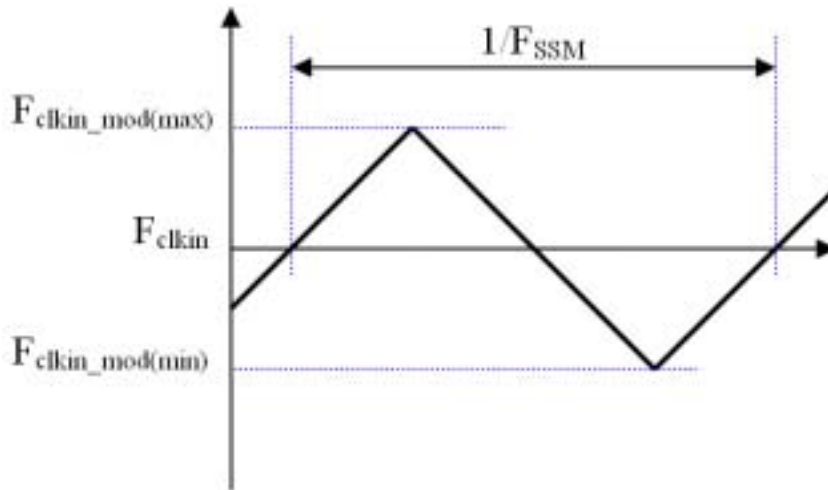

Note (3) The LVDS timing diagram and setup/hold time is defined and showing as the following figures.

**LVDS RECEIVER INTERFACE TIMING DIAGRAM**

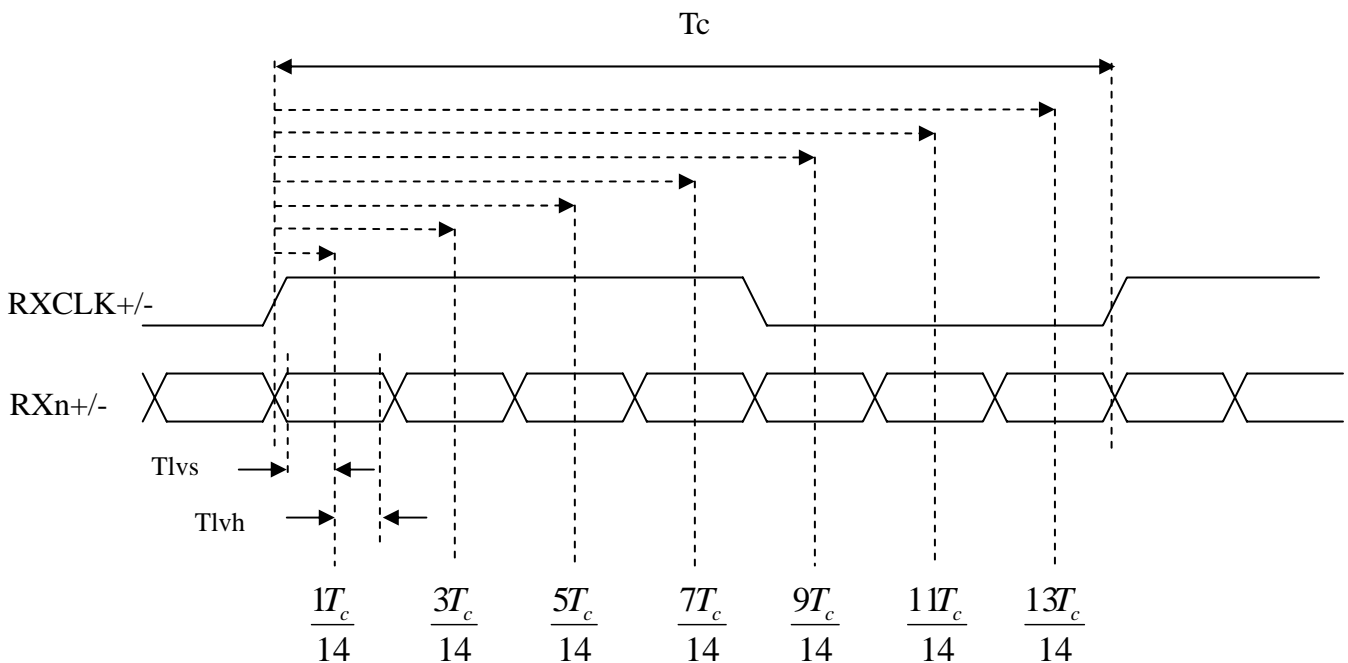

## 6.2 POWER ON/OFF SEQUENCE

To prevent a latch-up or DC operation of LCD module, the power on/off sequence should be as the diagram below.

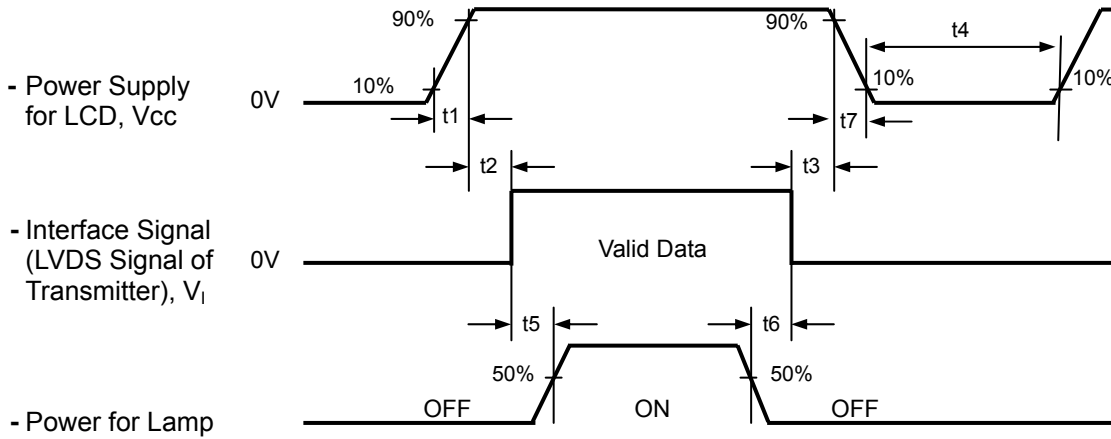

### Timing Specifications:

0.5 < t <sub>1</sub>	10 msec
0 < t <sub>2</sub>	50 msec
0 < t <sub>3</sub>	50 msec
t <sub>4</sub>	500 msec
t <sub>5</sub>	450 msec
t <sub>6</sub>	90 msec
5 t <sub>7</sub>	100 msec

### Note.

- (1) The supply voltage of the external system for the module input should be the same as the definition of V<sub>cc</sub>.
- (2) Apply the lamp voltage within the LCD operation range. When the backlight turns on before the LCD operation of the LCD turns off before the backlight turns off, the display may momentarily become abnormal screen.
- (3) In case of V<sub>CC</sub> = off level, please keep the level of input signals on the low or keep a high impedance.
- (4) T<sub>4</sub> should be measured after the module has been fully discharged between power off and on period.
- (5) Interface signal shall not be kept at high impedance when the power is on.
- (6) The company will not guarantee or compensate for the product damage caused by not following the Power Sequence.

## 7. OPTICAL CHARACTERISTICS

### 7.1 TEST CONDITIONS

Item	Symbol	Value	Unit
Ambient Temperature	Ta	25±2	°C
Ambient Humidity	Ha	50±10	%RH
Gamma voltage	-	Refer to Item 3 driving condition	V
Vcom	-	most suitable Vcom	V

### 7.2 OPTICAL SPECIFICATIONS

ITEM		Symbol	Condition	MIN.	TYP.	MAX.	UNIT	NOTE
Contrast Ratio		CR	$\theta_x=\theta_y=0^\circ$ CS-1000T	700	1000	-	%	(3),(1)
Response Time (Black/White)		Tr	$\theta_x=\theta_y=0^\circ$	---	1.3	2.2	ms	(4)
		Tf	$\theta_x=\theta_y=0^\circ$	---	3.7	5.8	ms	(4)
Center point Transmittance		T%	$\theta_x=\theta_y=0^\circ$ CS-1000T	5.8	6.9	-	%	(8),(1), (5)
Transmittance uniformity (9pts)		T%	$\theta_x=\theta_y=0^\circ$	-	1.3	1.42	-	(7),(1)
Viewing Angle	Horizontal $\theta_x$ ( $\theta_y=0^\circ$ )	Right	CR 10 USB-2000	75	85	-	Deg	(2),(6), (1)
		Left		75	85	-	Deg	
	Vertical $\theta_y$ ( $\theta_x=0^\circ$ )	Up		70	80	-	Deg	
		Down		70	80	-	Deg	
Color Coordinate at center point	Red	Rcx	$\theta_x=\theta_y=0$ DMS 803	Typ -0.03	0.648	Typ +0.03	-	(6),(0)
		Rcy			0.328		-	
	Green	Gcx			0.273		-	
		Gcy			0.580		-	
	Blue	Bcx			0.146		-	
		Bcy			0.102		-	
	White	Wcx			0.323		-	
		Wcy			0.361		-	

Note (0) Light source is the standard light source "C" which is defined by CIE and driving voltages are based on suitable gamma voltages.

Note (1) Light source is the BLU(M200O1-L01), which is supplied by CMO, and driving voltages are based on suitable gamma voltages. White is without signal input and R, G, B are with signal input. SPEC is judged by CMO's golden sample.

Note (2) Definition of Viewing Angle ( $\theta_x, \theta_y$ ):

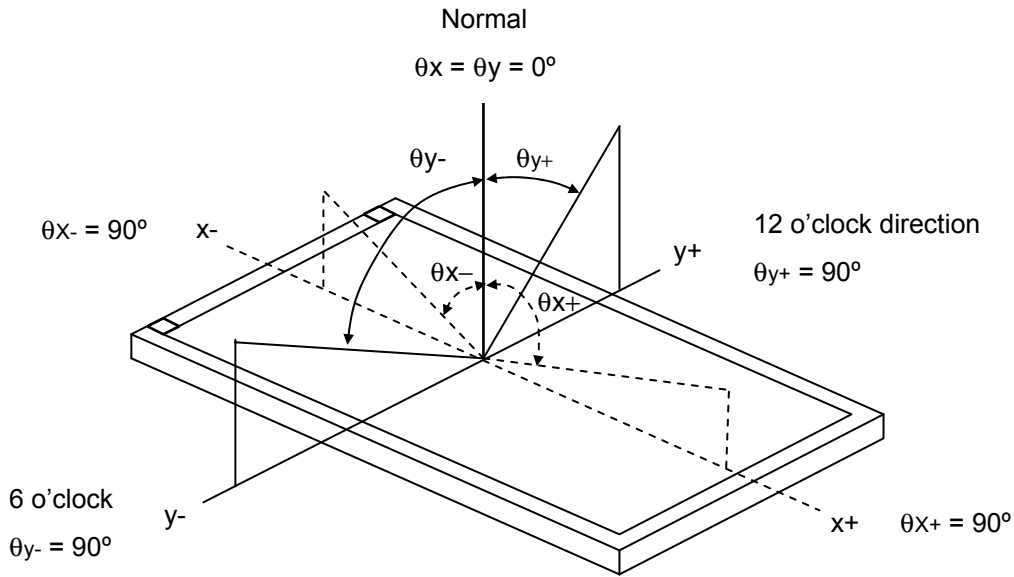

Note (3) Definition of Contrast Ratio (CR):

The contrast ratio can be calculated by the following expression.

$$\text{Contrast Ratio (CR)} = L_{255} / L_0$$

L255: Luminance of gray level 255

L 0: Luminance of gray level 0

$$\text{CR} = \text{CR} (5)$$

CR (X) is corresponding to the Contrast Ratio of the point X at Figure in Note (7).

Note (4) Definition of Response Time ( $T_R, T_F$ ):

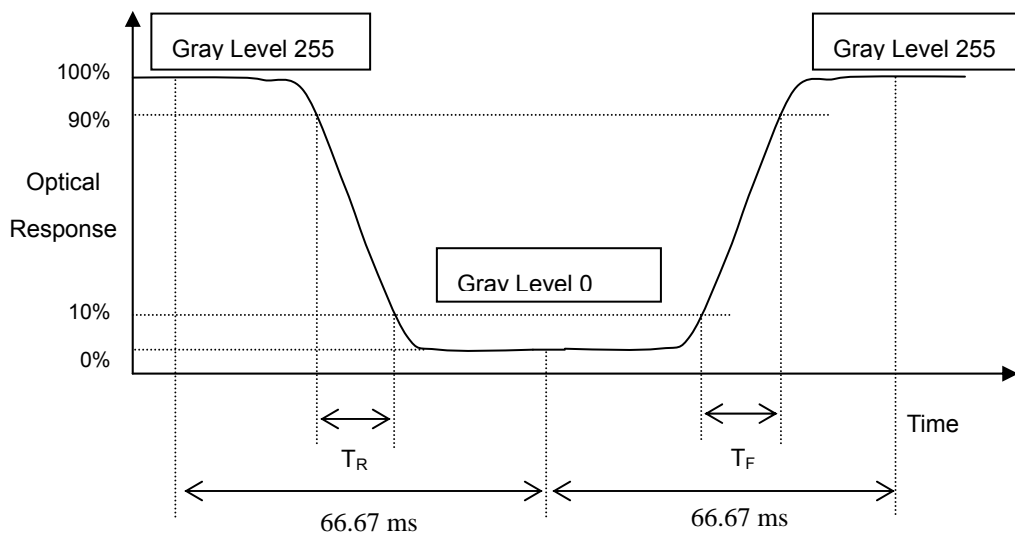

Note (5) Definition of Luminance of White ( $L_C$ ):

Measure the luminance of gray level 255 at center point

$$L_C = L(5)$$

$L(x)$  is corresponding to the luminance of the point X at Figure in Note (7).

Note (6) Measurement Setup:

The LCD module should be stabilized at given temperature for 30 minutes to avoid abrupt temperature change during measuring. In order to stabilize the luminance, the measurement should be executed after lighting Backlight for 30 minutes in a windless room.

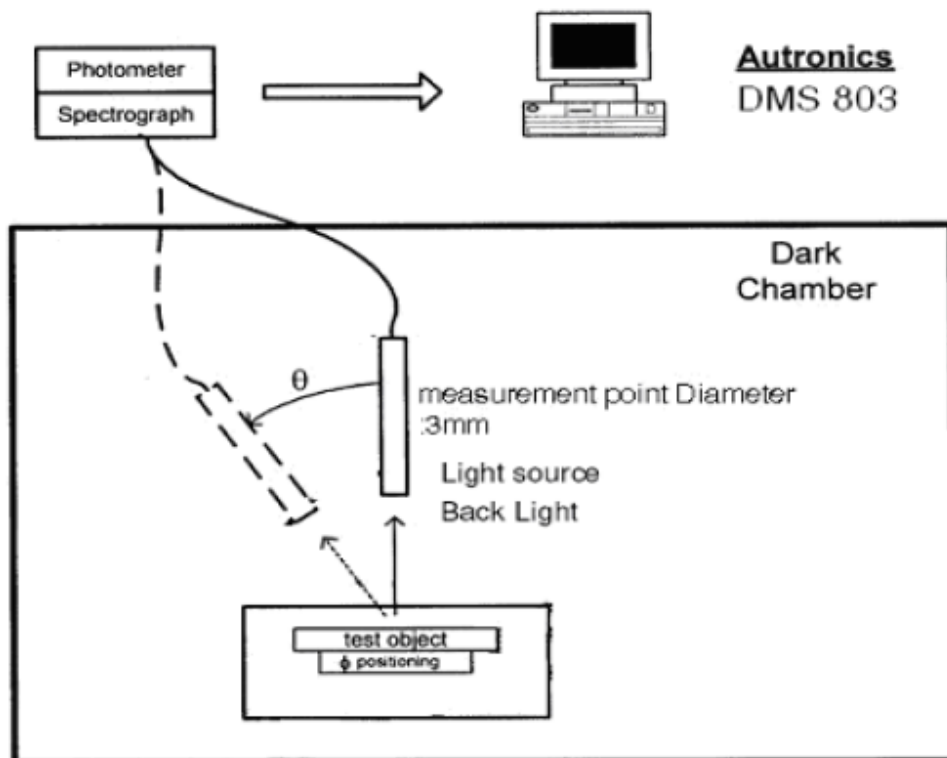
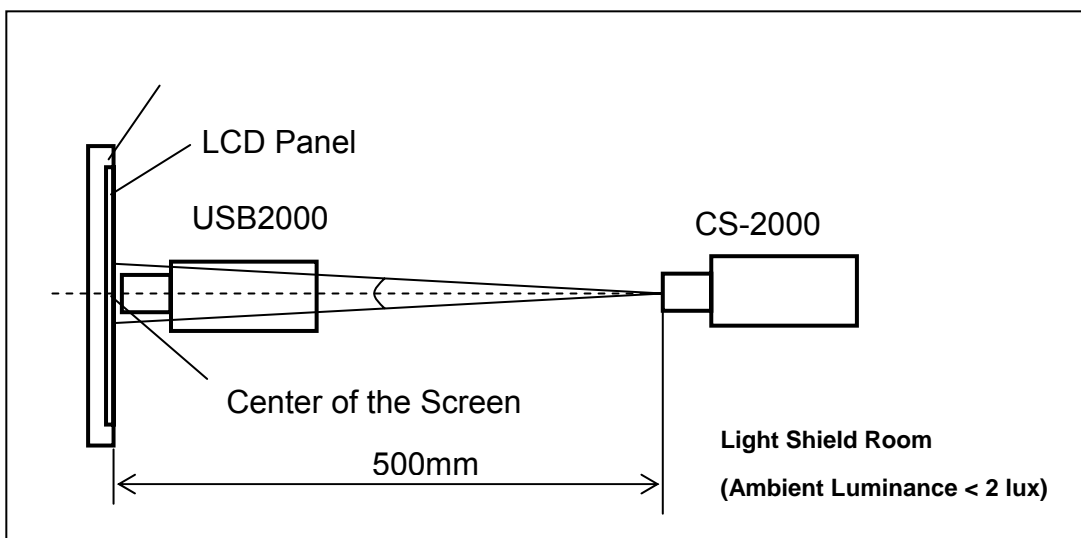

Note (7) Definition of Transmittance Variation ( $\delta T\%$ ):

Measure the transmittance at 9 points

$$T\% = \frac{\text{Maximum } [T\%(1), T\%(2), \dots T\%(9)]}{\text{Minimum } [T\%(1), T\%(2), \dots T\%(9)]}$$

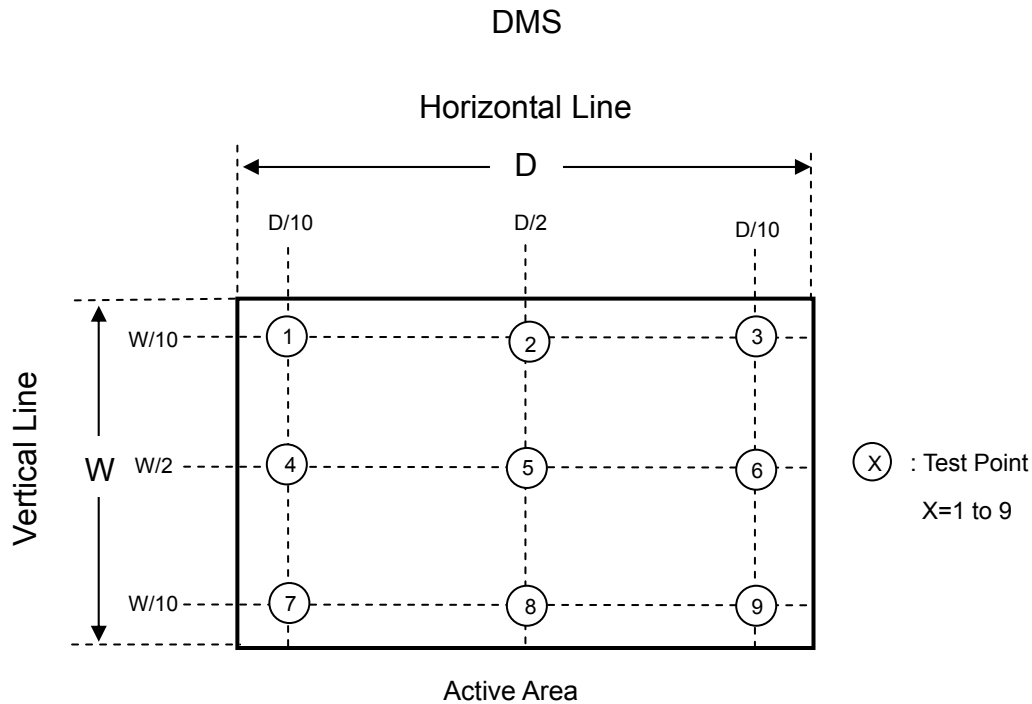

Note (8) Definition of Transmittance ( $T\%$ ):

Module is without signal input.

BLU is supplied by CMO

$$\text{Transmittance} = \frac{\text{Luminance of LCD module}}{\text{Luminance of backlight}} * 100\%$$

### 7.3 Flicker Adjustment

Flicker must be finely adjusted after module assembling and aging. Please follow below instructions.

(1) Adjustment Pattern: 2H1V checker pattern as follows.

R	G	B	R	G	B	R	G	B	R	G	B	R	G	B	R	G	B	R	G	B	R	G	B
R	G	B	R	G	B	R	G	B	R	G	B	R	G	B	R	G	B	R	G	B	R	G	B
R	G	B	R	G	B	R	G	B	R	G	B	R	G	B	R	G	B	R	G	B	R	G	B
R	G	B	R	G	B	R	G	B	R	G	B	R	G	B	R	G	B	R	G	B	R	G	B
R	G	B	R	G	B	R	G	B	R	G	B	R	G	B	R	G	B	R	G	B	R	G	B
R	G	B	R	G	B	R	G	B	R	G	B	R	G	B	R	G	B	R	G	B	R	G	B
R	G	B	R	G	B	R	G	B	R	G	B	R	G	B	R	G	B	R	G	B	R	G	B
R	G	B	R	G	B	R	G	B	R	G	B	R	G	B	R	G	B	R	G	B	R	G	B
R	G	B	R	G	B	R	G	B	R	G	B	R	G	B	R	G	B	R	G	B	R	G	B



(2) Adjustment Method:

Flicker should be adjusted by turning the volume for flicker adjustment by the ceramic driver. It is adjusted to the point with least flickering of the whole screen. After making it surely overrun at once, it should be adjusted to the optimum point.

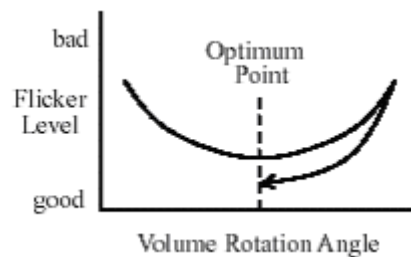

## 8. PACKAGING

### 8.1 PACKING SPECIFICATIONS

- (1) 24 open cells / 1 Box
- (2) Box dimensions: 570 (L) X 450 (W) X 320 (H) mm
- (3) Weight: approximately 21Kg (24 open cells per box)

### 8.2 PACKING METHOD

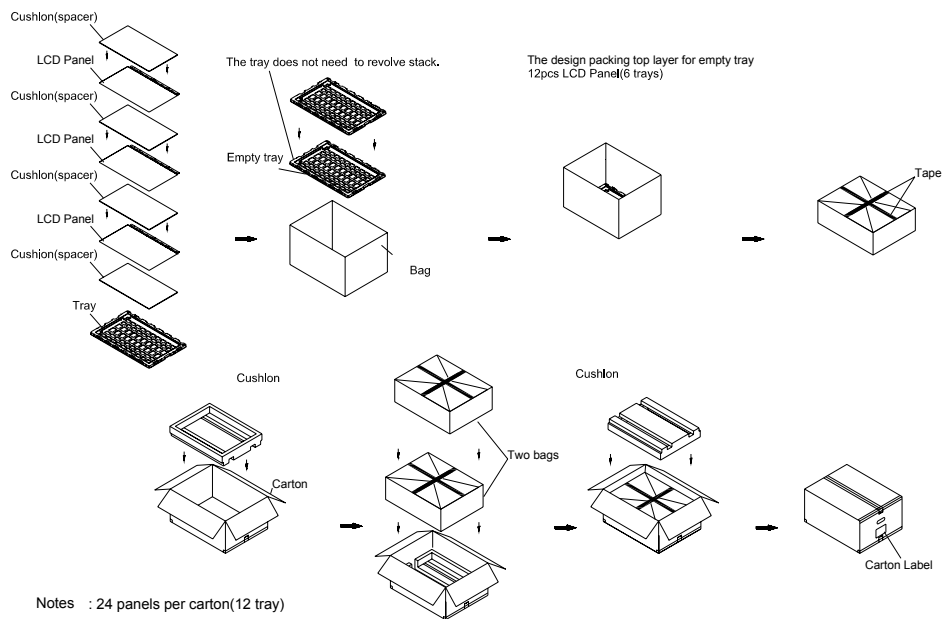

Sea and Land Transportation

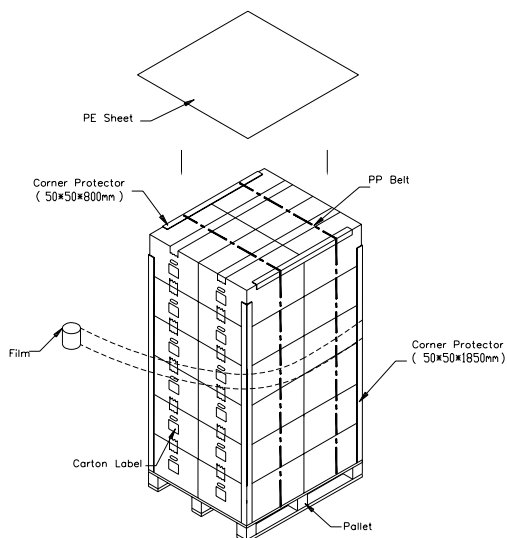

Air Transportation

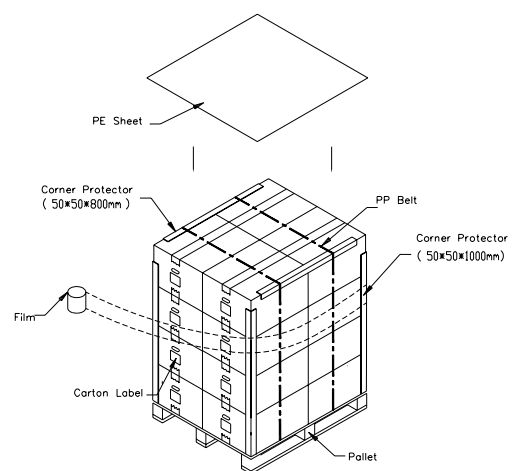

## 9. DEFINITION OF LABELS

### 9.1 CMO OPEN CELL LABEL

The barcode nameplate is pasted on each OPEN CELL as illustration for CMO internal control.



Barcode definition:

Serial ID: CM-20012-X-X-X-XX-L-XX-L-YMD-NNNN

Code	Meaning	Description
CM	Supplier code	CMO=CM
20012	Model number	M200O1-P02=20012
X	Revision code	C1:1 ,C2:2.....
X	Source driver IC code	Century=1, CLL=2, Demos=3, Epson=4, Fujitsu=5, Himax=6, Hitachi=7, Hynix=8, LDI=9, Matsushita=A, NEC=B, Novatec=C, OKI=D, Philips=E, Renasas=F, Samsung=G, Sanyo=H, Sharp=I, TI=J, Topro=K, Toshiba=L, Windbond=M
X	Gate driver IC code	
XX	Cell location	Tainan, Taiwan=TN
L	Cell line #	1,2,~,9,A,B,~,Y,Z
XX	Module location	Tainan, Taiwan=TN
L	Module line #	1,2,~,9,A,B,~,Y,Z
YMD	Year, month, day	Year: 2001=1, 2002=2, 2003=3, 2004=4... Month: 1~12=1, 2, 3, ~, 9, A, B, C Day: 1~31= 1, 2, 3, ~, 9, A, B, C, ~, T, U, V
NNNN	Serial number	Manufacturing sequence of product

### 9.2 CARTON LABEL

The barcode nameplate is pasted on each box as illustration, and its definitions are as following explanation



- (a) Model Name: M200O1 -P02
- (b) Carton ID: CMO internal control
- (c) Quantities: 24 pcs

## 10. RELIABILITY TEST

Environment test conditions are listed as following table.

Items	Required Condition	Note
Temperature Humidity Bias (THB)	Ta= 50 , 80%RH, 240hours	(1)
High Temperature Operation (HTO)	Ta= 50 , 50%RH , 240hours	
Low Temperature Operation (LTO)	Ta= 0 , 240hours	
High Temperature Storage (HTS)	Ta= 60 , 240hours	
Low Temperature Storage (LTS)	Ta= -20 , 240hours	
Package Vibration Test	ISTA STANDARD 1.14Grms Random, Frequency Range: 1 ~ 200 Hz Top & Bottom: 30 minutes (+Z), 10 min (-Z), Right & Left: 10 minutes (X) Back & Forth 10 minutes (Y)	(2)
Thermal Shock Test (TST)	-20 /30min, 60 / 30min, 100 cycles	(1)
On/Off Test	25 , On/10sec, Off /10sec, 30000 cycles	
Altitude Test	Operation: 10000 ft / 24hours Non-Operation: 30000 ft / 24hours	

Note (1) The tests are done with LCD modules (M200O1-L02).

Note (2) The test is done with a package shown in Section 8.

## 11. PRECAUTIONS

### 11.1 ASSEMBLY AND HANDLING PRECAUTIONS

- (1) Do not apply rough force such as bending or twisting to the product during assembly.
- (2) To assemble backlight or install module into user's system can be only in clean working areas. The dust and oil may cause electrical short or worsen the polarizer.
- (3) It is not permitted to have pressure or impulse on the module because the LCD panel will be damaged.
- (4) Always follow the correct power sequence when the product is connecting and operating. This can prevent damage to the CMOS LSI chips during latch-up.
- (5) Do not pull the I/F connector in or out while the module is operating.
- (6) Use a soft dry cloth without chemicals for cleaning, because the surface of polarizer is very soft and easily scratched.
- (7) It is dangerous that moisture come into or contacted the product, because moisture may damage the product when it is operating.
- (8) High temperature or humidity may reduce the performance of module. Please store this product within the specified storage conditions.
- (9) When ambient temperature is lower than 10°C may reduce the display quality. For example, the response time will become slowly.

### 11.2 SAFETY PRECAUTIONS

- (1) If the liquid crystal material leaks from the panel, it should be kept away from the eyes or mouth. In case of contact with hands, skin or clothes, it has to be washed away thoroughly with soap.
- (2) After the product's end of life, it is not harmful in case of normal operation and storage.

### 11.3 OTHER

- (1) When fixed patterns are displayed for a long time, remnant image is likely to occur.

## 12. MECHANICAL DRAWING

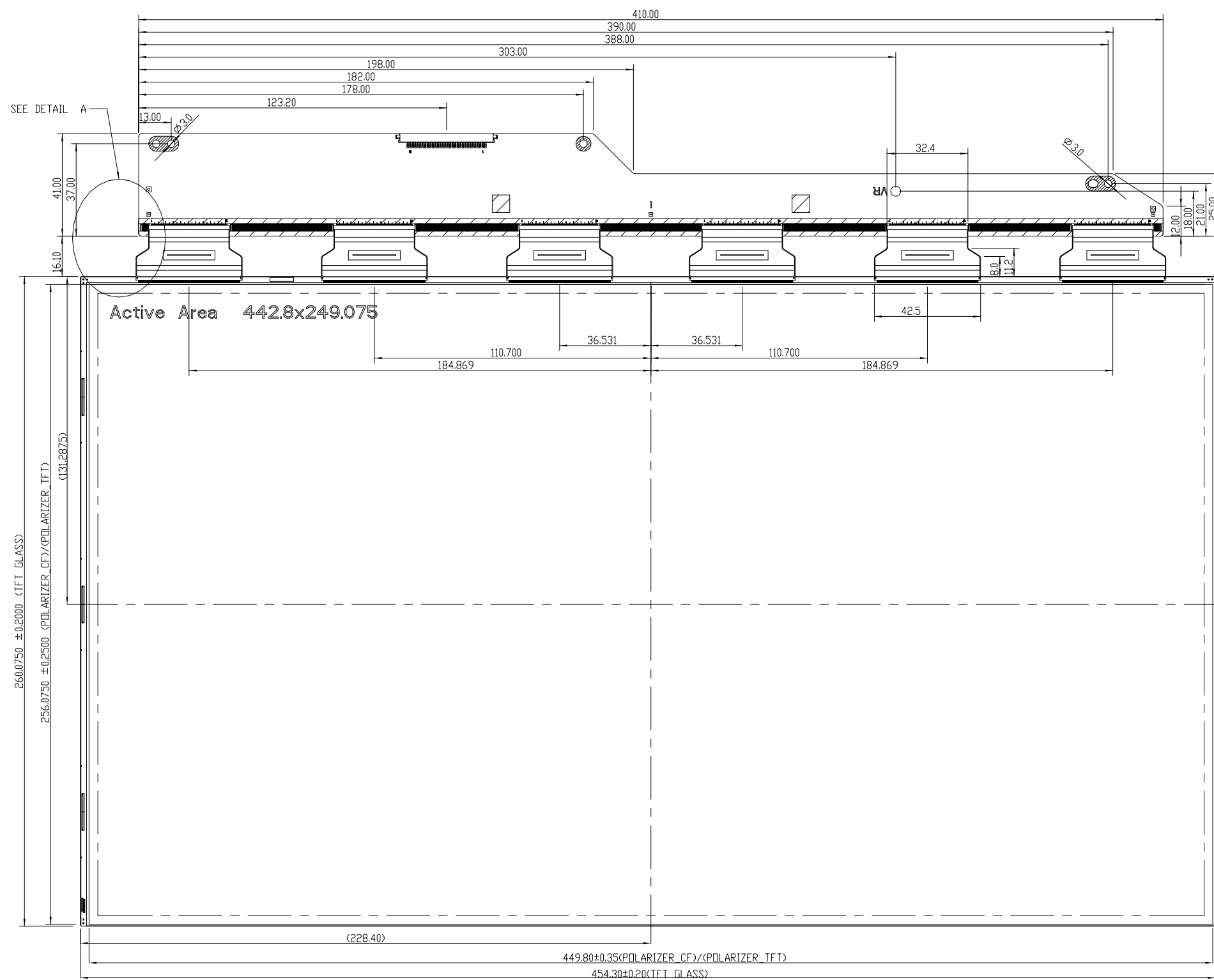

SCALE 1:1

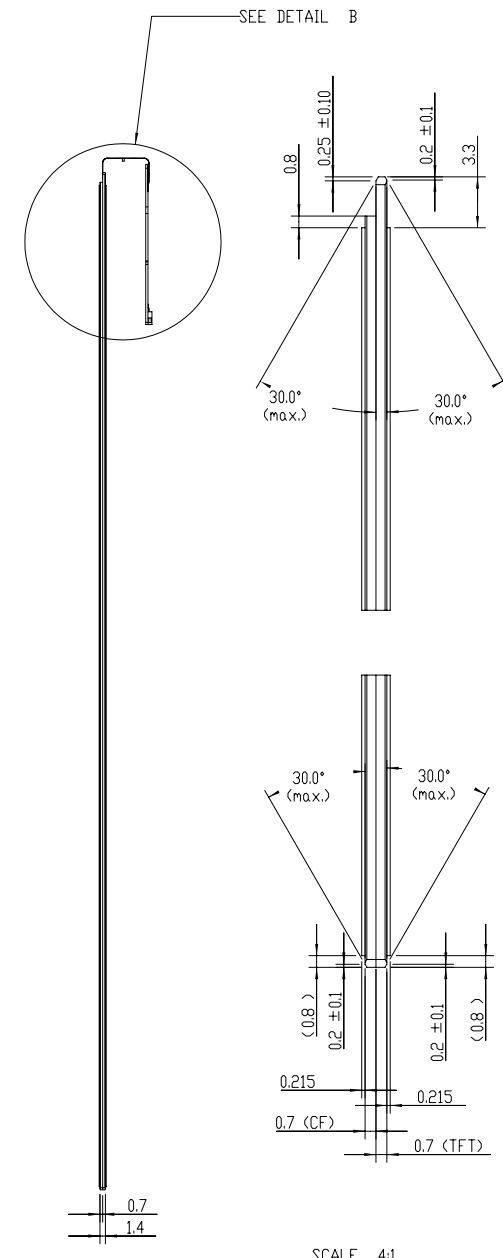

SCALE 1:1

SCALE 4:1

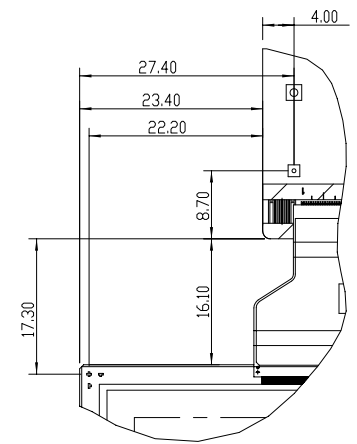

DETAIL A  
SCALE 2:1

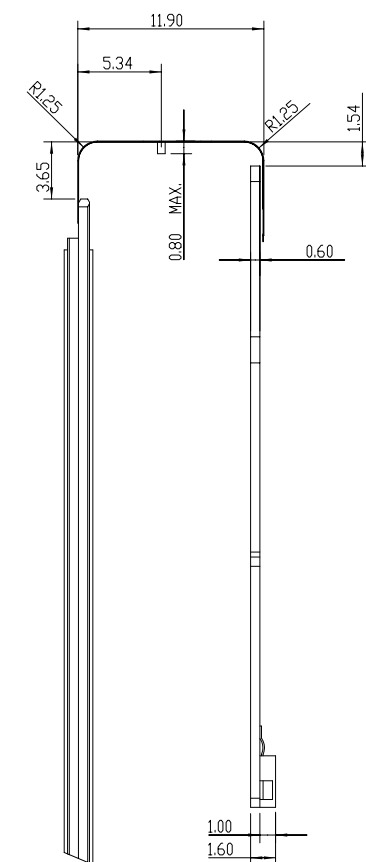

DETAIL B  
SCALE 4:1

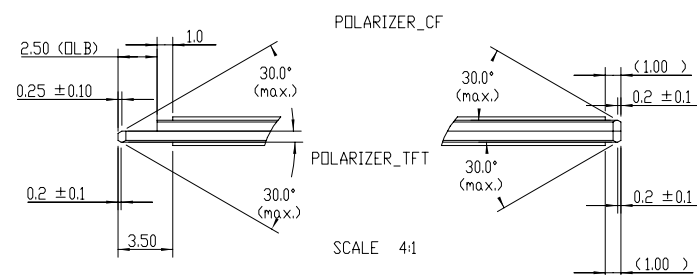

TITLE	PANEL_CDF_PCB_M20001-P02	2D REV. A	3D REV. 11
Approved	YULE-LIN	Drawing No.	M20014108A
Checked	ALAN_LEE	Part No.	TBD
Drawer	JS_JIANG	Material	TBD
Designer	JS_JIANG	Date	2009.4.9
		Scale	1:1
		Unit	mm
		CHI MEI OPTOELECTRONICS CORP. ALL RIGHTS RESERVED. COPYING FORBIDDEN.	

Mark	Description	Date	Changed_By	Approved_By	ECN No.	Remark
1						
2						
3						
4						